



Seamlessly blending into your dynamic office ecosystem.

Product features

- User-friendly web-based key management software solution
- Networked or Standalone
- Notification emails
- Audible and visual alarms
- Multi-authentication supported
- Mechanical lock and internal memory backup during power outages
- Reliable anti-tamper cable seals for enhanced security
- 5 years warranty included

Specifications

Modelsu	Capacity	Dimensions	Net weight
A-180E	18 key positions	500 (W) x 400 (H) x 189 (D) mm	17 kg
Construction			
Material	<i>1.5 mm steel, powder coated</i>		
Color	white		
Door	Steel door with hole / Solid steel (options)		
Door Lock	Electric Motor Freezer Lock		
Key Tag	Plastic flat tag with security seal		
Mounting	Wall mount		
Power			
Power supply	Input: 110V - 240V AC Output: 12V DC		
Power consumption	12V 2amp max		
Certifications	CE, FCC, RoHS, ISO9001		
Controller			
Operating system	based on Android		
Display	7" touch screen		
Data storage	RAM 1GB + ROM 8GB		
Server	Cloud platform / Local server		
RFID type	125Khz / 13.56Mhz (optional)		
Cabinet access	PIN code, Card ID, Fingerprint, Face recognition (options) <i>(Optional combination of any two methods for authentication)</i>		
Communications			
Network	Ethernet TCP/IP / Wifi		
USB	Support		

Series A
A-180E

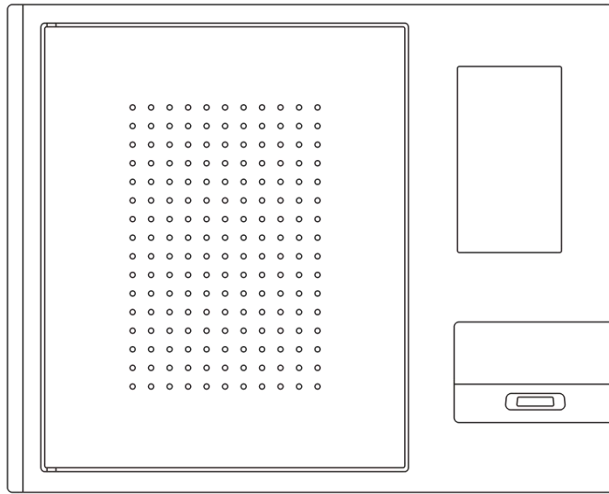

500mm

Front View

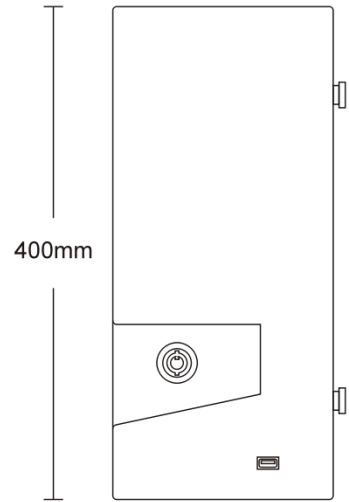

400mm

189mm

Side View

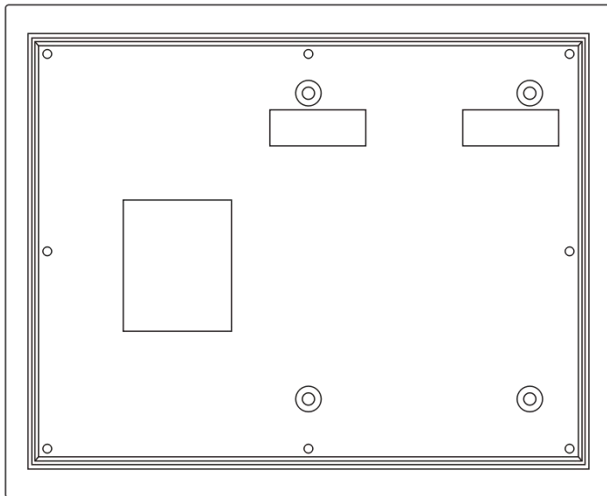

Rear View

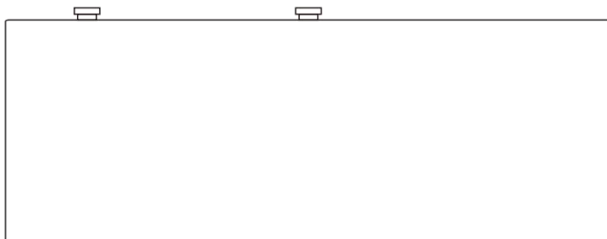

Top View